



# LINEAR BAR GRILLES ■



[www.airmasteremirates.com](http://www.airmasteremirates.com)



# INDEX

SECTION	TOPIC	PAGE
3.1	<b>Double deflection linear bar grille ASLG</b>	3
3.2	<b>Double deflection linear bar register ASLR</b>	4
3.3	<b>Single deflection linear bar grille ARLG</b>	5
3.4	<b>Single deflection linear bar register ARLR</b>	6
3.5	<b>Double deflection curved linear bar grille ASLG (C)</b>	7
3.6	<b>Double deflection linear bar register with 6 mm pitch ASLR (S)</b>	8
3.7	<b>Standard finishes and Mitered options</b>	9
3.8	<b>Bar deflections</b>	10
3.9	<b>Accessories and Fixing details</b>	11
3.10	<b>Fixing details, Standard sizes and Product summary</b>	12
3.19	<b>Double security bar register AMSR-D</b>	21
3.20	<b>Maximum security perforated grille AMPSG</b>	22
3.22	<b>Light duty floor grille AFG-L</b>	24
3.24	<b>Heavy duty floor grille AFG-H</b>	26
3.25	<b>Heavy duty floor grille-SS AFG-H (SS)</b>	27
<b>AIR FLOW DATA</b>		
3.11	<b>Double deflection linear bar register 15°- 2 way - 12 mm spacing ASLR/ASLG</b>	13
3.12	<b>Double deflection linear bar register 15°- 1 way - 12 mm spacing ASLR-1/ASLG-1</b>	14
3.13	<b>Double deflection linear bar register 0° - 12 mm spacing ASLR-0/ASLG-0</b>	15
3.14	<b>Single deflection linear bar register 15°- 2 way - 12 mm spacing ARLR/ARLG</b>	16
3.15	<b>Single deflection linear bar register 15°-1 way - 12 mm spacing ARLR-1/ARLG-1</b>	17
3.16	<b>Single deflection linear bar register 0° - 12 mm spacing ARLR-0/ARLG-0</b>	18
3.17	<b>Double deflection linear bar register 15°- 2 way - 6 mm spacing ASLR (S)/ASLG (S)</b>	19
3.18	<b>Single deflection linear bar register 15°- 2 way - 6 mm spacing ARLR (S)/ARLG (S)</b>	20
3.21	<b>Maximum security perforated grille AMPSG</b>	23
3.23	<b>Light duty floor grille AFG-L</b>	25

## CONSTRUCTION:

**Frame:** High quality extruded aluminium profile with 30 mm flange width as standard. 12, 20, 24 mm flange widths are optional.

**Face bars:** High quality aluminium profiles of 0°, 15°-1 way throw and 15°-2 way throw.

**Bar spacing:** 12 mm as standard. 6 mm as option.

**Grille width:** 50 mm to 300 mm with increments of 50 mm.

## Description:

- Frame and face bars are of high quality extruded aluminium profiled construction with the advantages of corrosion resistance and rigidity.
- Horizontal face bars with 0°, 15°-1 way throw and 15°-2 way throw are fixed rigidly to the frame with 8 mm pipes.
- Vertical aluminium aerofoil blades are fixed at the rear side of the frame by nylon bushes. These blades can be adjusted manually and individually in the vertical plane to obtain optimum air distribution.
- For perfect unbroken appearance of continuous runs, alignment strips are provided with no additional cost.
- Total structure is manufactured by mechanical assembly, assuring rigidity and to maintain straight line appearance.
- Supplied with C-clamps for concealed fixing.

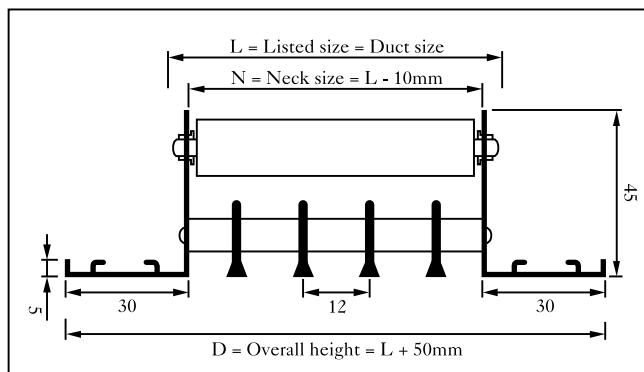
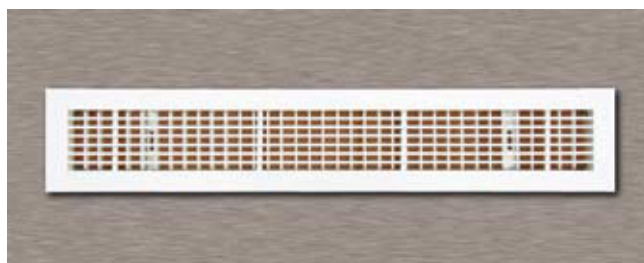

**CONSTRUCTION:**

**Frame:** High quality extruded aluminium profile with 30 mm flange width as standard. 12, 20, 24 mm flange widths are optional.

**Face bars:** High quality aluminium profiles of 0°, 15°-1 way throw and 15°-2 way throw.

**Bar spacing:** 12 mm as standard. 6 mm as option.

**Grille width:** 50 mm to 300 mm with increments of 50 mm.

**Damper frame and blades:** High quality extruded aluminium profiles with natural aluminium finish. Black matt finish as option.

**Description:**

- Frame and face bars are of high quality extruded aluminium profiled construction with the advantages of corrosion resistance and rigidity.
- Horizontal face bars with 0°, 15°-1 way throw and 15°-2 way throw are fixed rigidly to the frame with 8 mm pipes.
- Vertical aluminium aerofoil blades are fixed at the rear side of the frame by nylon bushes. These blades can be adjusted manually and individually in the vertical plane to obtain optimum air distribution.
- Grilles are fixed rigidly with an opposed blade damper by grippers to ensure positive control over the air stream. Damper blades can be screw operated from the face opening of the grille.
- Provided with alignment strip for continuous appearance. Foam gasket is sealed around the back of the frame to avoid air leakage.
- Supplied with C-clamps for concealed fixing.

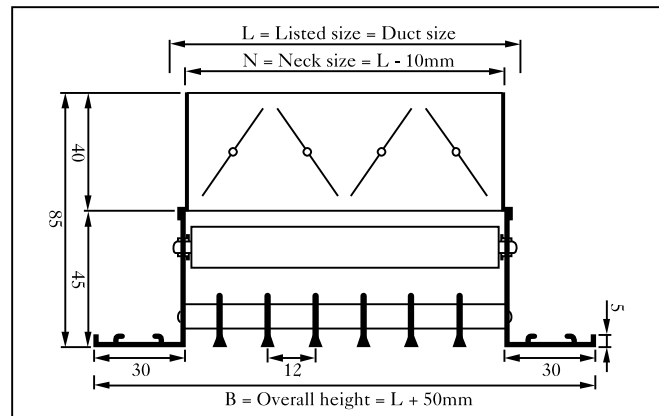
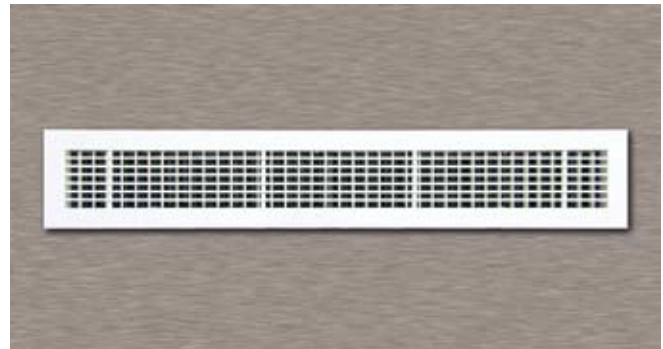

## CONSTRUCTION:

**Frame:** High quality extruded aluminium profile with 30 mm flange width as standard. 12, 20, 24 mm flange widths are optional.

**Face bars:** High quality aluminium profiles of 0°, 15°-1 way throw and 15°-2 way throw.

**Bar spacing:** 12 mm as standard. 6 mm as option.

**Grille width:** 50 mm to 300 mm with increments of 50 mm.

## Description:

- Frame and face bars are of high quality extruded aluminium profiled construction with the advantages of corrosion resistance and rigidity.
- Horizontal face bars with 0°, 15°-1 way throw and 15°-2 way throw are fixed rigidly to the frame with 8 mm pipes.
- For perfect unbroken appearance of continuous runs, alignment strips are provided with no additional cost.
- Total structure is manufactured by mechanical assembly, assuring rigidity and to maintain straight line appearance.
- Supplied with C-clamps for concealed fixing.

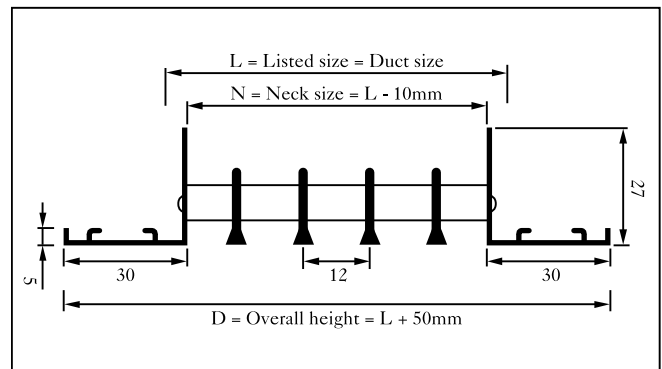
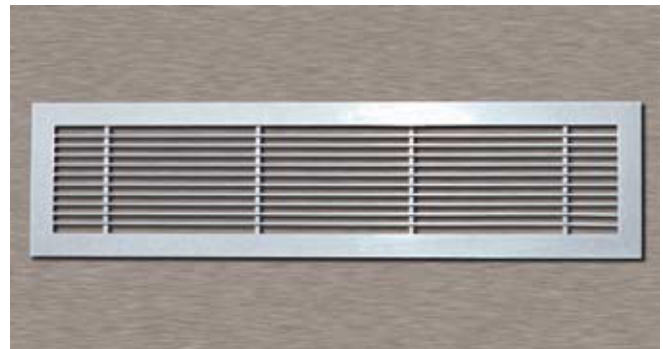

**CONSTRUCTION:**

**Frame:** High quality extruded aluminium profile with 30 mm flange width as standard. 12, 20, 24 mm flange widths are optional.

**Face bars:** High quality aluminium profiles of 0°, 15°-1 way throw and 15°-2 way throw.

**Bar spacing:** 12 mm as standard. 6 mm as option.

**Grille width:** 50 mm to 300 mm with increments of 50 mm.

**Damper frame and blades:** High quality extruded aluminium profiles with natural aluminium finish. Black matt finish as option.

**Description:**

- Frame and face bars are of high quality extruded aluminium profiled construction with the advantages of corrosion resistance and rigidity.
- Horizontal face bars with 0°, 15°-1 way throw and 15°-2 way throw are fixed rigidly to the frame with 8 mm pipes.
- Grilles are fixed rigidly with opposed blade damper by grippers. This ensures positive control over the air stream. Damper blades can be screw operated from the face opening.
- For perfect unbroken appearance of continuous runs, alignment strips are provided with no additional cost.
- Foam gasket is sealed around the back of the frame as option to avoid air leakage.
- Supplied with C-clamps for concealed fixing.

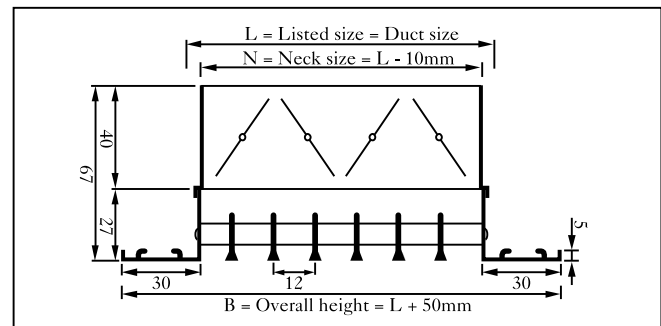
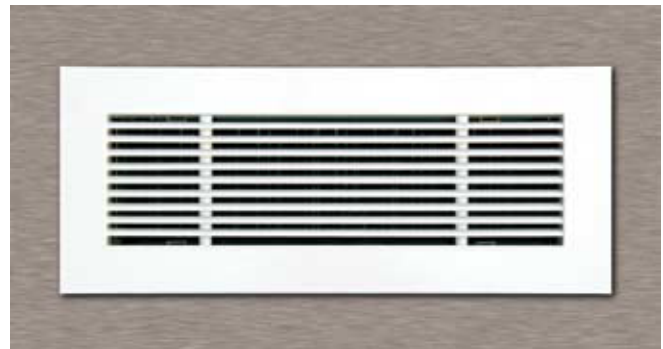

## CONSTRUCTION:

**Frame:** High quality extruded aluminium profile with 30 mm flange width (Std.). 12, 20, 24 mm flange widths (optional).

**Face bars:** High quality aluminium profiles of 0°-1 way throw and 15°-2 way throw.

**Bar spacing:** 12 mm (Std.), 6 mm (Optional).

**Grille width:** 50 mm to 300 mm with increments of 50 mm.



## Description:

- Frame and face bars are of high quality extruded aluminium profiled construction with the advantages of corrosion resistance and rigidity.
- Horizontal face bars with 0°-1 way throw and 15°-2 way throw are fixed rigidly to the frame with 8 mm pipes.
- Vertical aluminium aerofoil blades are fixed at the rear side of the frame by nylon bushings. These blades can be adjusted manually and individually in the vertical plane to obtain optimum air distribution.
- For perfect unbroken appearance of continuous runs, alignment strips are provided with no additional cost.
- Curved linear bar grilles are available up to a length of 3 meter with a minimum radius of curvature of 1 meter.
- Available without damper. Dampers can be provided to use in plenum boxes as option.
- Foam gasket is sealed around the back of the frame as option to avoid air leakage.
- Supplied with C-clamps for concealed fixing.
- Standard application on curved walls.

**Model: ARLG-C:** Same as ASLG-C, without vertical aerofoil blades.

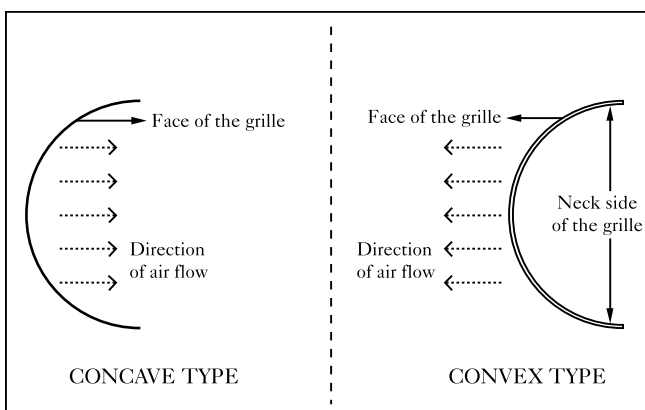
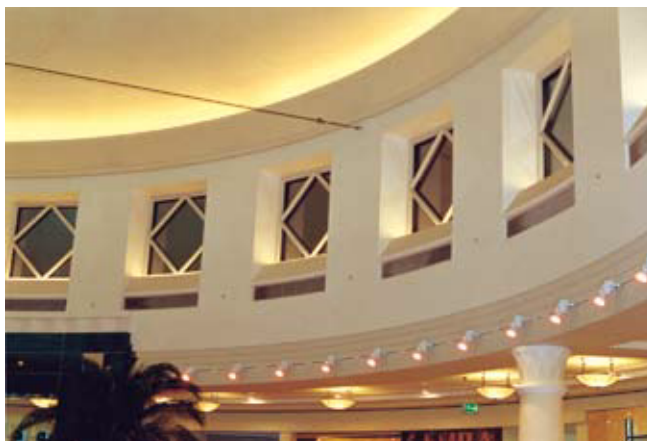
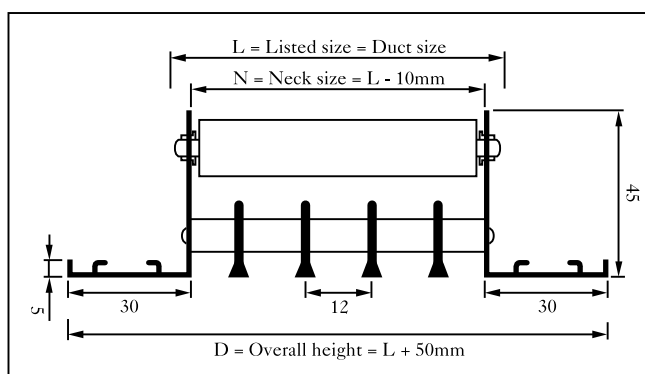

**CONSTRUCTION:**

**Frame:** High quality extruded aluminium profile with 30 mm flange width as standard. 12, 20, 24 mm flange widths are optional.

**Face bars:** High quality aluminium profiles of 0°, 15°-1 way throw and 15°-2 way throw.

**Bar spacing:** 6 mm.

**Grille width:** 50 mm to 300 mm with increments of 50 mm.

**Damper frame and blades:** High quality extruded aluminium profiles with natural aluminium finish. Black matt finish as option.

**Description:**

- Frame and face bars are of high quality extruded aluminium profiled construction with the advantages of corrosion resistance and rigidity.
  - Horizontal face bars with 0°, 15°-1 way throw and 15°-2 way throw are fixed rigidly to the frame with 8 mm pipes.
  - Vertical aluminium aerofoil blades are fixed at the rear side of the frame by nylon bushings. These blades can be adjusted manually and individually in the vertical plane to obtain optimum air distribution.
  - Grilles are fixed rigidly with an opposed blade damper by grippers to ensure positive control over the air stream. Damper blades can be screw operated from the face opening of the grille.
  - For perfect unbroken appearance of continuous runs, alignment strips are provided with no additional cost. Foam gasket is sealed around the back of the frame as option to avoid air leakage.
  - Supplied with C-clamps for concealed fixing.
  - Also available without damper and vertical blades for return air applications.
- Model: ARLG (S)**

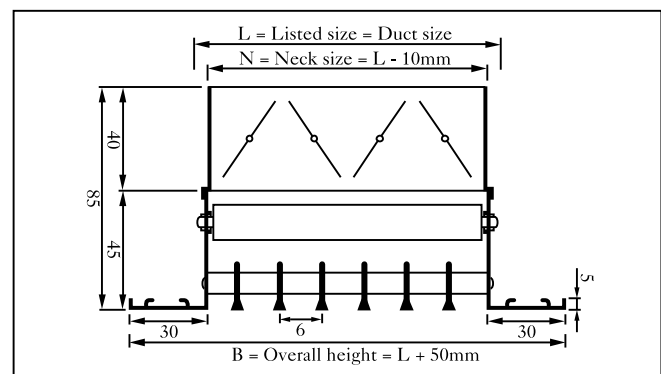



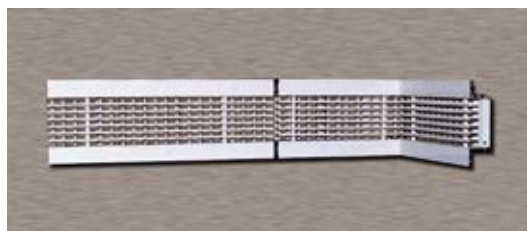

## Standard finishes:

- Natural anodized aluminum finish.
- Powder coated colour finish as per RAL colour codes.
- Flexibility of finishing is available as option.

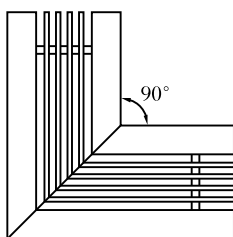

3a) 90° Horizontal

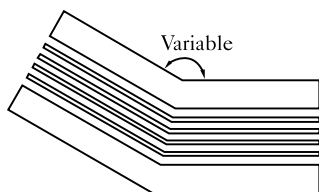

3b) Variable angle(90°- 180°)

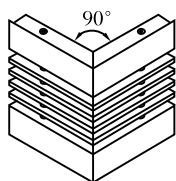

3c) 90° Vertical outside

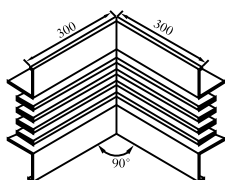

3d) 90° Vertical inside

## Optional mitered corners

Standard 90° horizontal mitered corner available for floor, sill and ceiling applications in 0°, 15°-1 way throw and 15°-2 way throw without damper.

Special horizontal mitered corner selection available for floor, sill and ceiling applications includes an angle greater than 90° and less than 180° available in 0°, 15°-1 way throw and 15°-2 way throw without damper.

Vertical outside mitered corners are available for wall application at the junction of two outside walls with a standard angle of 90°. Available in 0°, 15°-1 way throw and 15°-2 way throw without damper.

Special horizontal mitered corner selection available for floor, sill and ceiling applications includes an angle greater than 90° and less than 180° available in 0°, 15°-1 way throw and 15°-2 way throw without damper.



## Bar deflections

### Standard:

MODEL	0° one way	15° one way	15° two way
ASLG			
ASLR			
ARLG			
ARLR			

### Blade options:

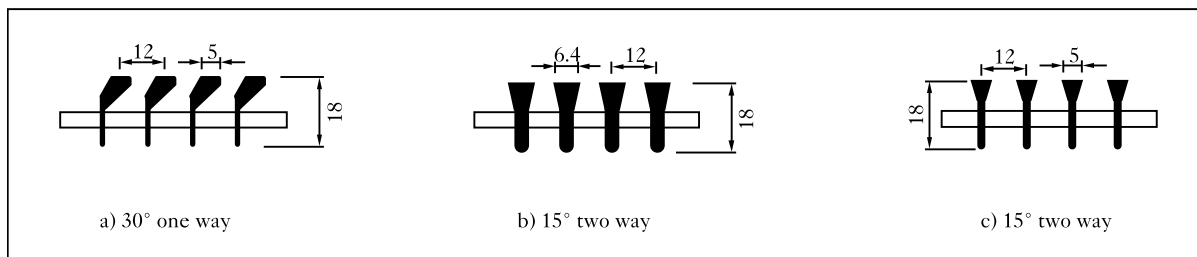

## ACCESSORIES:

### END FLANGES:

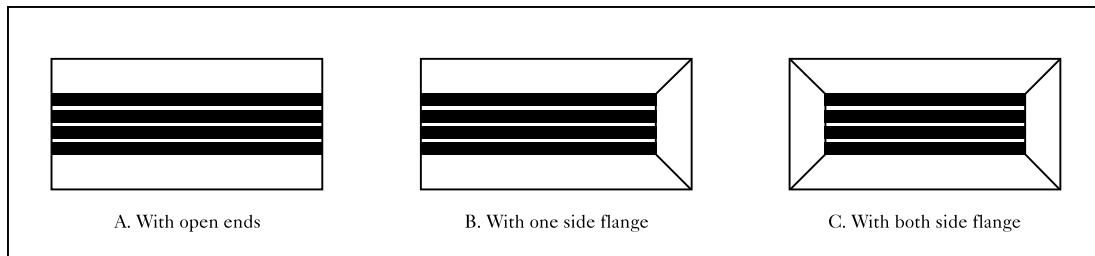

### LINEAR BAR GRILLE WITH ONE SIDE ACCESS DOOR:

Access door will be provided either right or left side of the grille for special applications upon request. Size of the door is optional.

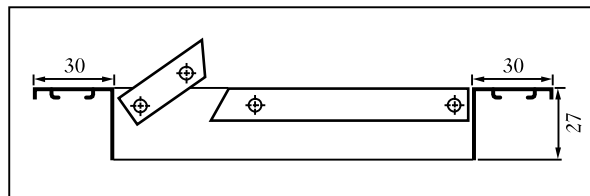
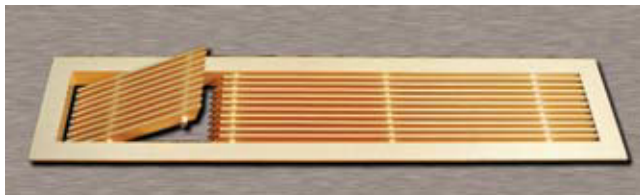

### LINEAR BAR GRILLE WITH BOTH SIDE ACCESS DOOR:

Access door will be provided to both sides of the grille for special applications upon request. Size of the door is optional.

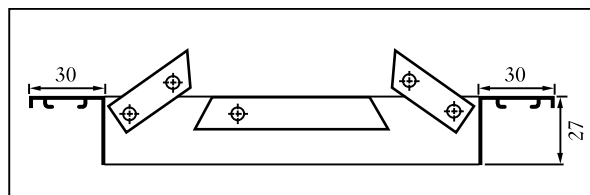
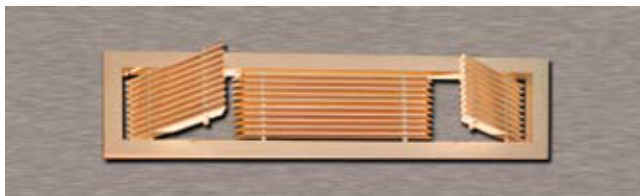

## FIXING DETAILS:

### C-Clamp fixing:

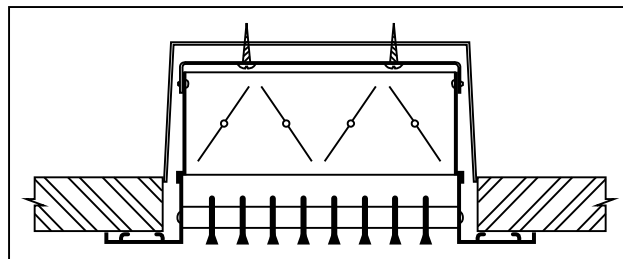
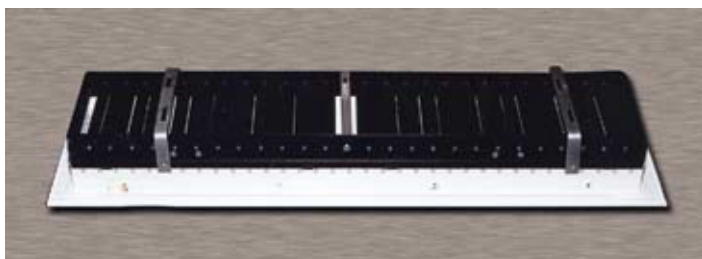

### Fixing details:

#### Fixing to the plenum box:

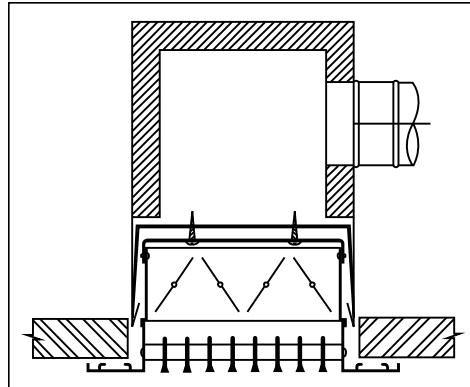

### Standard sizes:

- Grilles are available with 1 meter length as standard.
- Length from 0.2 meter to 5.8 meter is available as single piece.
- Non standard sizes available as option.

Listed Width in mm	50	100	150	200	250	300
--------------------	----	-----	-----	-----	-----	-----

### Product summary:

Model Number	Product Description	Remarks
ASLG	Double deflection bar grille	<ul style="list-style-type: none"> <li>• 12 mm bar space</li> <li>• Face bar options               <ul style="list-style-type: none"> <li>- 0°</li> <li>- 15° 1-way</li> <li>- 15° 2-way</li> </ul> </li> </ul>
ASLR	Double deflection bar register	
ARLG	Single deflection bar grille	
ARLR	Single deflection bar register	
ASLR(S)	Double deflection bar register – 6 mm bar spacing	Also available without damper and vertical blades for return application.
ASLG-C	Double deflection bar grille – curved	<ul style="list-style-type: none"> <li>• 12 mm bar space</li> <li>• Face bar option               <ul style="list-style-type: none"> <li>- 0°</li> <li>- 15° 2-way</li> </ul> </li> </ul>
ARLG-C	Single deflection bar grille – curved	

### Product order checklist:

- Model
- Length and width in mm x mm
- Face bar (0°, 15°-1 way, 15°-2 way)
- End flange details (open end, one side flange or both side flange)
- Quantity
- Colour (RAL 9010, 9016, Anodised aluminium finish or other RAL colours)
- Drawing or template necessary for curved bar grille.

**Table 3.1 Air flow data**

Width in mm $A_k$ in m <sup>2</sup>	Face Velocity in m/sec.	2.0	2.5	3.0	3.5	4.0	4.5	5.0
<b>50</b>	Cfm	165	207	248	290	330	373	413
	M <sup>3</sup> /sec.	0.078	0.098	0.117	0.137	0.156	0.176	0.195
	P <sub>s</sub> in mm H <sub>2</sub> O	0.15	0.21	0.21	0.25	0.32	0.4	0.51
	Throw in m	2.7-4.0-5.5	3.4-4.3-6.0	4.0-4.9-6.7	4.3-5.2-7.3	4.6-5.5-7.6	4.9-5.8-8.2	4.9-6.0-8.5
	NC	<15	<15	<15	16	22	25	30
<b>100</b>	Cfm	250	313	375	438	500	563	625
	M <sup>3</sup> /sec.	0.118	0.148	0.177	0.207	0.236	0.266	0.295
	P <sub>s</sub> in mm H <sub>2</sub> O	0.15	0.21	0.21	0.3	0.39	0.51	0.61
	Throw in m	3.4-4.6-7.0	4.0-5.2-7.6	4.6-5.8-8	5.2-6.0-8.5	5.5-6.7-9.1	5.8-7.3-10	6-7.6-10.7
	NC	<15	<15	<15	17	22	27	31
<b>150</b>	Cfm	330	413	495	578	660	743	825
	M <sup>3</sup> /sec.	0.156	0.195	0.234	0.273	0.312	0.351	0.39
	P <sub>s</sub> in mm H <sub>2</sub> O	0.15	0.21	0.25	0.36	0.46	0.58	0.71
	Throw in m	4.0-5.5-8.0	4.6-6.0-8.8	5.2-6.7-9.5	5.8-7.3-10	6.4-8-10.7	6.7-8.5-11.6	7-8.8-12.2
	NC	<15	<15	<15	17	23	28	32
<b>200</b>	Cfm	410	515	616	718	821	925	1027
	M <sup>3</sup> /sec.	0.194	0.243	0.291	0.339	0.388	0.437	0.485
	P <sub>s</sub> in mm H <sub>2</sub> O	0.2	0.23	0.31	0.39	0.53	0.66	0.91
	Throw in m	4.5-6.1-8.8	5.2-6.7-9.8	6.0-7.6-10.7	6.7-8.0-11.3	7.3-8.8-11.9	7.6-9.5-12.8	8.0-9.8-13.7
	NC	<15	<15	16	21	26	31	35
<b>250</b>	Cfm	491	614	736	860	982	1105	1228
	M <sup>3</sup> /sec.	0.232	0.29	0.348	0.406	0.464	0.522	0.58
	P <sub>s</sub> in mm H <sub>2</sub> O	0.2	0.25	0.33	0.43	0.58	0.76	0.94
	Throw in m	4.9-6.7-9.8	5.5-7.6-10.7	6.4-8.2-11.3	7.3-8.8-12.2	8.0-9.5-13.1	8.2-10-14	8.5-10.7-15
	NC	<15	<15	20	25	31	34	37
<b>300</b>	Cfm	576	720	864	1008	1152	1295	1440
	M <sup>3</sup> /sec.	0.272	0.34	0.408	0.476	0.544	0.612	0.68
	P <sub>s</sub> in mm H <sub>2</sub> O	0.2	0.31	0.36	0.47	0.64	0.85	1.02
	Throw in m	5.2-7.3-10.7	6.1-8.2-11.6	7-9.1-12.2	7.9-9.8-13.1	8.5-10.4-14	8.8-11-15	9.1-11.6-16.2
	NC	<15	18	24	28	32	35	40

- Data based on one meter unit length of the grille with damper in full open position.
- Face velocity is measured in m/sec.
- P<sub>s</sub>: Static pressure loss is in mm of H<sub>2</sub>O.
- Throw (meters) is measured for a terminal velocities of 0.75, 0.5 & 0.25 m/sec.
- NC based on a room attenuation of 10 dB.

# DOUBLE DEFLECTION LINEAR BAR REGISTER

## 15°-1 Way - 12 mm spacing

model: **ASLR-1/ASLG-1**
**air master**  
ISO 9001 CERTIFIED COMPANY

**Table 3.2 Air flow data**

Width in mm $A_k$ in $m_2$	Face Velocity in m/sec.	2.0	2.5	3.0	3.5	4.0	4.5	5.0
<b>50</b>	Cfm	169	212	254	296	339	381	423
	M <sup>3</sup> /sec.	0.08	0.1	0.12	0.14	0.16	0.18	0.2
	P <sub>s</sub> in mm H <sub>2</sub> O	0.14	0.19	0.21	0.25	0.31	0.39	0.5
	Throw in m	2.7-4.1-5.6	3.5-4.4-6.2	4.1-5.0-7.0	4.5-5.4-7.7	4.8-5.8-8.1	5.1-6.1-8.9	5.2-6.4-9.3
	NC	<15	<15	<15	17	22	25	31
<b>100</b>	Cfm	275	345	413	483	550	620	688
	M <sup>3</sup> /sec.	0.13	0.163	0.195	0.228	0.26	0.293	0.325
	P <sub>s</sub> in mm H <sub>2</sub> O	0.14	0.19	0.21	0.3	0.38	0.5	0.6
	Throw in m	3.5-4.7-7.1	4.1-5.3-7.8	4.7-5.9-8.4	5.4-6.2-9.0	5.8-7.0-9.7	6.1-7.7-10.8	6.4-8.1-11.7
	NC	<15	<15	15	18	23	27	32
<b>150</b>	Cfm	373	466	559	652	745	838	932
	M <sup>3</sup> /sec.	0.176	0.22	0.264	0.308	0.352	0.396	0.44
	P <sub>s</sub> in mm H <sub>2</sub> O	0.14	0.19	0.25	0.36	0.45	0.57	0.7
	Throw in m	4.1-5.6-8.2	4.7-6.2-9.0	5.4-6.9-10	6.0-7.6-10.6	6.7-8.4-11.4	7.0-8.9-12.5	7.4-9.3-13.3
	NC	<15	<15	16	18	24	29	34
<b>200</b>	Cfm	470	589	705	824	940	1058	1175
	M <sup>3</sup> /sec.	0.222	0.278	0.333	0.389	0.444	0.499	0.555
	P <sub>s</sub> in mm H <sub>2</sub> O	0.18	0.21	0.31	0.39	0.52	0.65	0.9
	Throw in m	4.6-6.2-9.0	5.3-6.9-10.0	6.2-7.8-11.2	6.9-8.3-11.9	7.7-9.2-12.7	8.9-9-13.8	8.5-10.4-14.9
	NC	<15	16	17	21	26	32	36
<b>250</b>	Cfm	567	709	851	993	1135	1277	1419
	M <sup>3</sup> /sec.	0.268	0.335	0.402	0.469	0.536	0.603	0.67
	P <sub>s</sub> in mm H <sub>2</sub> O	0.2	0.25	0.33	0.42	0.56	0.77	0.93
	Throw in m	5.0-6.8-10	5.6-7.8-11	6.6-8.4-11.9	7.6-9.2-12.9	8.4-10-14	8.6-10.5-15.1	9.0-11.3-16.4
	NC	<15	16	21	27	31	35	40
<b>300</b>	Cfm	686	857	1029	1200	1372	1543	1715
	M <sup>3</sup> /sec.	0.324	0.405	0.486	0.567	0.648	0.729	0.81
	P <sub>s</sub> in mm H <sub>2</sub> O	0.2	0.3	0.36	0.47	0.64	0.84	1.01
	Throw in m	5.3-7.5-10.9	6.2-8.4-11.9	7.2-9.4-12.8	8.2-10.2-13.9	8.9-10.9-15	9.2-11.6-16.2	9.6-12.3-17.6
	NC	<15	18	25	30	33	37	42

- Data based on one meter unit length of the grille with damper in full open position.
- Face velocity is measured in m/sec.
- P<sub>s</sub>: Static pressure loss is in mm of H<sub>2</sub>O.
- Throw (meters) is measured for a terminal velocities of 0.75, 0.5 & 0.25 m/sec.
- NC based on a room attenuation of 10 dB.

**Table 3.3 Air flow data**

Width in mm $A_k$ in m <sup>2</sup>	Face Velocity in m/sec.	2.0	2.5	3.0	3.5	4.0	4.5	5.0
<b>50</b>	Cfm	169	212	254	296	339	381	423
	M <sup>3</sup> /sec.	0.08	0.1	0.12	0.14	0.16	0.18	0.2
	P <sub>s</sub> in mm H <sub>2</sub> O	0.14	0.19	0.19	0.23	0.28	0.36	0.46
	Throw in m	2.7-4.1-5.6	3.5-4.4-6.2	4.2-5.1-7.1	4.6-5.6-7.9	4.9-5.6-8.3	5.4-6.4-9.3	5.5-6.8-9.8
	NC	<15	<15	<15	17	22	25	31
<b>100</b>	Cfm	275	345	413	483	550	620	688
	M <sup>3</sup> /sec.	0.13	0.163	0.195	0.228	0.26	0.293	0.325
	P <sub>s</sub> in mm H <sub>2</sub> O	0.14	0.19	0.19	0.28	0.35	0.46	0.56
	Throw in m	3.5-4.7-7.1	4.1-5.3-7.8	4.8-6.0-8.6	5.6-6.4-9.3	5.9-7.2-10.0	6.4-8.1-11.3	6.8-8.6-12.4
	NC	<15	<15	15	18	23	27	32
<b>150</b>	Cfm	373	466	559	652	745	838	932
	M <sup>3</sup> /sec.	0.176	0.22	0.264	0.308	0.352	0.396	0.44
	P <sub>s</sub> in mm H <sub>2</sub> O	0.14	0.19	0.23	0.33	0.42	0.53	0.65
	Throw in m	4.1-5.6-8.2	4.7-6.2-9.0	5.5-7-10.2	6.2-7.8-10.9	6.9-8.7-11.7	7.4-9.3-13.1	7.8-9.8-14.0
	NC	<15	<15	16	18	24	29	34
<b>200</b>	Cfm	470	589	705	824	940	1058	1175
	M <sup>3</sup> /sec.	0.222	0.278	0.333	0.389	0.444	0.499	0.555
	P <sub>s</sub> in mm H <sub>2</sub> O	0.16	0.19	0.28	0.36	0.48	0.6	0.84
	Throw in m	4.6-6.2-9.0	5.3-6.9-10.0	6.3-7.9-11.4	7.1-8.5-12.3	7.9-9.5-13.1	8.4-10.4-14.5	9.0-11.0-15.8
	NC	<15	16	17	21	26	32	36
<b>250</b>	Cfm	567	709	851	993	1135	1277	1419
	M <sup>3</sup> /sec.	0.268	0.335	0.402	0.469	0.536	0.603	0.67
	P <sub>s</sub> in mm H <sub>2</sub> O	0.19	0.23	0.31	0.39	0.52	0.71	0.86
	Throw in m	5.0-6.8-10	5.6-7.8-11	6.7-8.6-12.1	7.8-9.5-13.3	8.6-10.3-14.4	9.0-11-15.9	9.5-11.9-17.4
	NC	<15	16	21	27	31	35	40
<b>300</b>	Cfm	686	857	1029	1200	1372	1543	1715
	M <sup>3</sup> /sec.	0.324	0.405	0.486	0.567	0.648	0.729	0.81
	P <sub>s</sub> in mm H <sub>2</sub> O	0.19	0.28	0.33	0.44	0.59	0.78	0.94
	Throw in m	5.3-7.5-10.9	6.2-8.4-11.9	7.3-9.6-13.0	8.4-10.5-14.3	9.2-11.2-15.4	9.6-12.2-17.0	10.2-13-18.6
	NC	<15	18	25	30	33	37	42

- Data based on one meter unit length of the grille with damper in full open position.
- Face velocity is measured in m/sec.
- P<sub>s</sub>: Static pressure loss is in mm of H<sub>2</sub>O.
- Throw (meters) is measured for a terminal velocities of 0.75, 0.5 & 0.25 m/sec.
- NC based on a room attenuation of 10 dB.

# SINGLE DEFLECTION LINEAR BAR REGISTER

## 15°-2 Way - 12 mm spacing



**air master**  
ISO 9001 CERTIFIED COMPANY

### Table 3.4 Air flow data

Nominal Width mm							
50	Cfm	332	417	500	585	667	750
	M <sup>3</sup> /sec.	0.157	0.197	0.236	0.276	0.315	0.354
	P <sub>s</sub> in mm H <sub>2</sub> O	0.48	0.74	1.07	1.47	1.91	2.41
	NC	<15	18	26	32	36	42
100	Cfm	417	500	585	667	750	833
	M <sup>3</sup> /sec.	0.197	0.236	0.276	0.315	0.354	0.393
	P <sub>s</sub> in mm H <sub>2</sub> O	0.51	0.71	0.97	1.27	1.6	1.98
	NC	15	20	27	32	35	40
150	Cfm	500	585	667	750	833	1000
	M <sup>3</sup> /sec.	0.236	0.276	0.315	0.354	0.393	0.472
	P <sub>s</sub> in mm H <sub>2</sub> O	0.51	0.69	0.89	1.14	1.40	2.01
	NC	17	22	28	32	34	38
200	Cfm	585	667	750	833	1000	1167
	M <sup>3</sup> /sec.	0.276	0.315	0.354	0.393	0.472	0.551
	P <sub>s</sub> in mm H <sub>2</sub> O	0.48	0.64	0.81	0.99	1.42	1.91
	NC	16	23	26	32	35	40
250	Cfm	667	750	833	1000	1167	1332
	M <sup>3</sup> /sec.	0.315	0.354	0.393	0.472	0.551	0.629
	P <sub>s</sub> in mm H <sub>2</sub> O	0.48	0.61	0.74	1.07	1.45	1.9
	NC	19	23	25	31	35	40
300	Cfm	750	833	1000	1167	1333	1500
	M <sup>3</sup> /sec.	0.354	0.393	0.472	0.551	0.629	0.708
	P <sub>s</sub> in mm H <sub>2</sub> O	0.5	0.64	0.77	1.13	1.52	2.0
	NC	20	25	27	31	38	44

- Data based on one meter unit length of the grille.
- P<sub>s</sub>: Static pressure loss is in mm of H<sub>2</sub>O.
- NC based on a room attenuation of 10 dB.



**Table 3.5 Air flow data**

Nominal Width mm							
50	Cfm	332	417	500	585	667	750
	M <sup>3</sup> /sec.	0.157	0.197	0.236	0.276	0.315	0.354
	P <sub>s</sub> in mm H <sub>2</sub> O	0.46	0.72	1.03	1.42	1.88	2.32
	NC	<15	<18	25	31	31	40
100	Cfm	417	500	585	667	750	833
	M <sup>3</sup> /sec.	0.197	0.236	0.276	0.315	0.354	0.393
	P <sub>s</sub> in mm H <sub>2</sub> O	0.48	0.69	0.93	1.20	1.55	1.88
	NC	<15	19	24	31	34	38
150	Cfm	500	585	667	750	833	1000
	M <sup>3</sup> /sec.	0.236	0.276	0.315	0.354	0.393	0.472
	P <sub>s</sub> in mm H <sub>2</sub> O	0.48	0.67	0.86	1.10	1.34	1.92
	NC	15	20	27	31	31	37
200	Cfm	585	667	750	833	1000	1167
	M <sup>3</sup> /sec.	0.276	0.315	0.354	0.393	0.472	0.551
	P <sub>s</sub> in mm H <sub>2</sub> O	0.45	0.64	0.78	0.99	1.37	1.85
	NC	17	23	25	30	34	38
250	Cfm	667	750	833	1000	1167	1332
	M <sup>3</sup> /sec.	0.315	0.354	0.393	0.472	0.551	0.629
	P <sub>s</sub> in mm H <sub>2</sub> O	0.45	0.59	0.71	1.02	1.36	1.79
	NC	19	22	24	30	33	38
300	Cfm	750	833	1000	1167	1332	1500
	M <sup>3</sup> /sec.	0.354	0.393	0.472	0.551	0.629	0.708
	P <sub>s</sub> in mm H <sub>2</sub> O	0.48	0.6	0.74	1.05	1.45	1.8
	NC	19	23	25	30	37	42

- Data based on one meter unit length of the grille.
- P<sub>s</sub>: Static pressure loss is in mm of H<sub>2</sub>O.
- NC based on a room attenuation of 10 dB.

# SINGLE DEFLECTION LINEAR BAR REGISTER

0° - 12 mm spacing

model: **ARLR-0/ARLG-0**
**air master**  
ISO 9001 CERTIFIED COMPANY

**Table 3.6 Air flow data**

Nominal Width mm							
50	Cfm	332	417	500	585	667	750
	M <sup>3</sup> /sec.	0.157	0.197	0.236	0.276	0.315	0.354
	P <sub>s</sub> in mm H <sub>2</sub> O	0.43	0.69	0.99	1.37	1.83	2.23
	NC	<15	17	24	30	33	38
100	Cfm	417	500	585	667	750	833
	M <sup>3</sup> /sec.	0.197	0.236	0.276	0.315	0.354	0.393
	P <sub>s</sub> in mm H <sub>2</sub> O	0.45	0.66	0.89	1.14	1.48	1.78
	NC	<15	18	23	31	33	36
150	Cfm	500	585	667	750	833	1000
	M <sup>3</sup> /sec.	0.236	0.276	0.315	0.354	0.393	0.472
	P <sub>s</sub> in mm H <sub>2</sub> O	0.45	0.64	0.81	1.04	1.27	1.83
	NC	15	17	26	28	30	36
200	Cfm	585	667	750	833	1000	1167
	M <sup>3</sup> /sec.	0.276	0.315	0.354	0.393	0.472	0.551
	P <sub>s</sub> in mm H <sub>2</sub> O	0.43	0.64	0.65	0.91	1.4	1.8
	NC	17	22	24	27	33	37
250	Cfm	667	750	833	1000	1167	1332
	M <sup>3</sup> /sec.	0.315	0.354	0.393	0.472	0.551	0.629
	P <sub>s</sub> in mm H <sub>2</sub> O	0.43	0.56	0.66	0.94	1.27	1.67
	NC	19	21	23	29	32	36
300	Cfm	750	833	1000	1167	1330	1500
	M <sup>3</sup> /sec.	0.354	0.393	0.472	0.551	0.629	0.708
	P <sub>s</sub> in mm H <sub>2</sub> O	0.45	0.58	0.69	0.98	1.32	1.7
	NC	19	22	24	28	36	40

- Data based on one meter unit length of the grille.
- P<sub>s</sub>: Static pressure loss is in mm of H<sub>2</sub>O.
- NC based on a room attenuation of 10 dB.

**Table 3.7 Air flow data**

Width in mm $A_k$ in m <sup>2</sup>	Face Velocity in m/sec.	2.0	2.5	3.0	3.5	4.0	4.5	5.0
<b>50</b>	Cfm	85	106	127	148	169	190	212
	M <sup>3</sup> /sec.	0.04	0.05	0.06	0.07	0.08	0.09	0.1
	P <sub>s</sub> in mm H <sub>2</sub> O	0.16	0.23	0.23	0.28	0.36	0.45	0.59
	Throw in m	2.8-4.2-5.8	3.6-4.5-6.3	4.3-5.3-7.2	4.6-5.6-7.9	5.1-6.0-8.4	5.4-6.4-9.0	5.4-6.6-9.4
<b>0.02</b>	NC	<15	<15	<15	18	24	28	33
<b>100</b>	Cfm	148	186	222	260	296	335	370
	M <sup>3</sup> /sec.	0.07	0.088	0.105	0.123	0.14	0.158	0.175
	P <sub>s</sub> in mm H <sub>2</sub> O	0.16	0.23	0.23	0.33	0.44	0.58	0.7
	Throw in m	3.6-4.8-7.3	4.2-5.5-7.9	4.9-6.3-8.6	5.6-6.5-9.2	6.0-7.4-10.0	6.4-8.11	6.7-8.4-11.9
<b>0.035</b>	NC	<15	<15	17	20	25	29	34
<b>150</b>	Cfm	224	282	337	394	449	504	561
	M <sup>3</sup> /sec.	0.106	0.133	0.159	0.186	0.212	0.238	0.261
	P <sub>s</sub> in mm H <sub>2</sub> O	0.16	0.23	0.28	0.4	0.52	0.66	0.82
	Throw in m	4.2-5.8-8.4	4.8-6.3-9.2	5.6-7.2-10.3	6.3-7.9-10.8	7.0-8.8-11.8	7.4-9.4-12.8	7.8-9.8-13.5
<b>0.053</b>	NC	<15	<15	17	20	27	30	35
<b>200</b>	Cfm	284	356	426	498	567	639	709
	M <sup>3</sup> /sec.	0.134	0.168	0.201	0.235	0.268	0.302	0.335
	P <sub>s</sub> in mm H <sub>2</sub> O	0.22	0.25	0.34	0.43	0.6	0.75	1.05
	Throw in m	4.7-6.4-9.2	5.5-7-10.3	6.5-8.2-11.6	7.2-8.6-12.2	8-9.7-13.0	8.4-10.4-14	8.9-10.9-15.2
<b>0.067</b>	NC	<15	<15	18	23	29	34	39
<b>250</b>	Cfm	360	451	540	631	720	811	900
	M <sup>3</sup> /sec.	0.17	0.213	0.255	0.298	0.34	0.383	0.425
	P <sub>s</sub> in mm H <sub>2</sub> O	0.22	0.27	0.37	0.48	0.66	0.86	1.08
	Throw in m	5.1-7-10.3	5.7-7.9-11.2	6.9-8.8-12.2	7.9-9.5-13.2	8.8-10.4-14.4	9.0-11-15.4	9.4-11.9-16.6
<b>0.085</b>	NC	15	17	23	28	35	39	42
<b>300</b>	Cfm	436	546	654	764	872	982	1090
	M <sup>3</sup> /sec.	0.206	0.258	0.309	0.361	0.412	0.464	0.515
	P <sub>s</sub> in mm H <sub>2</sub> O	0.22	0.34	0.40	0.52	0.72	0.96	1.17
	Throw in m	5.4-7.7-11.2	6.4-8.6-12.2	7.6-9.8-13.2	8.5-10.6-14	9.4-11.4-15.4	9.7-12.1-16.5	10-12.9-18
<b>0.103</b>	NC	15	19	27	31	37	40	45

- Data based on one meter unit length of the grille with damper in full open position.
- Face velocity is measured in m/sec.
- P<sub>s</sub>: Static pressure loss is in mm of H<sub>2</sub>O.
- Throw (meters) is measured for a terminal velocities of 0.75, 0.5 & 0.25 m/sec.
- NC based on a room attenuation of 10 dB.

# SINGLE DEFLECTION LINEAR BAR REGISTER

## 15°-2 Way - 6 mm spacing



**air master**  
ISO 9001 CERTIFIED COMPANY

model: **ARLR (S)/ARLG (S)**

**Table 3.8 Air flow data**

Nominal Width mm							
50	Cfm	170	213	255	298	340	382
	M <sup>3</sup> /sec.	0.08	0.101	0.12	0.141	0.161	0.18
	P <sub>s</sub> in mm H <sub>2</sub> O	0.5	0.78	1.12	1.57	2.04	2.3
	NC	17	20	29	35	39	45
100	Cfm	247	296	347	395	445	494
	M <sup>3</sup> /sec.	0.117	0.139	0.164	0.187	0.21	0.233
	P <sub>s</sub> in mm H <sub>2</sub> O	0.54	0.75	1.02	1.36	1.7	2.13
	NC	17	22	30	35	38	44
150	Cfm	340	398	454	510	566	680
	M <sup>3</sup> /sec.	0.161	0.188	0.214	0.241	0.267	0.321
	P <sub>s</sub> in mm H <sub>2</sub> O	0.54	0.72	0.93	1.22	1.5	2.17
	NC	19	24	31	35	37	42
200	Cfm	404	461	518	576	691	806
	M <sup>3</sup> /sec.	0.191	0.218	0.245	0.272	0.326	0.381
	P <sub>s</sub> in mm H <sub>2</sub> O	0.51	0.67	0.85	1.06	1.52	2.06
	NC	18	25	29	35	38	44
250	Cfm	487	548	608	730	852	972
	M <sup>3</sup> /sec.	0.23	0.259	0.287	0.345	0.402	0.459
	P <sub>s</sub> in mm H <sub>2</sub> O	0.51	0.64	0.78	1.15	1.55	2.05
	NC	21	25	28	34	39	44
300	Cfm	570	633	760	887	1013	1140
	M <sup>3</sup> /sec.	0.269	0.299	0.359	0.419	0.478	0.538
	P <sub>s</sub> in mm H <sub>2</sub> O	0.53	0.67	0.81	1.21	1.63	2.16
	NC	22	27	30	34	42	47

- Data based on one meter unit length of the grille.
- P<sub>s</sub>: Static pressure loss is in mm of H<sub>2</sub>O.
- NC based on a room attenuation of 10 dB.

## CONSTRUCTION:

**Frame:** Heavy gauge high quality extruded aluminium profile with 30 mm flange width as standard.

**Face bars:** Heavy gauge extruded aluminium profiles of 0°, 15°-1 way throw and 15°-2 way throw. Steel bars are available as option.

**Bar spacing:** 12 mm.

**Damper frame and blades:** High quality extruded aluminium profiles with natural aluminium finish. Black matt finish as option.

## Standard finishes:

- Anodised finish.
- Powder coated as per RAL color codes.

## Description:

- Frame and face bars are of high quality extruded aluminium profiled construction with the advantages of corrosion resistance and rigidity.
- Horizontal face bars with 0°, 15°-1 way throw and 15°-2 way throw are fixed rigidly to the frame with steel rods welded to the main frame.
- Optional vertical aluminium aerofoil blades are fixed at the rear side of the frame by nylon bushings.
- Opposed blade damper is fixed to the main frame.

- Wall sleeves are made of heavy gauge galvanized steel.
- Security grilles are used in areas such as prisons, hospitals and production plants where security is of main concern.



## Fixing:

- Rivet fixing to the wall sleeve.
- Special damper proof screw fixing.

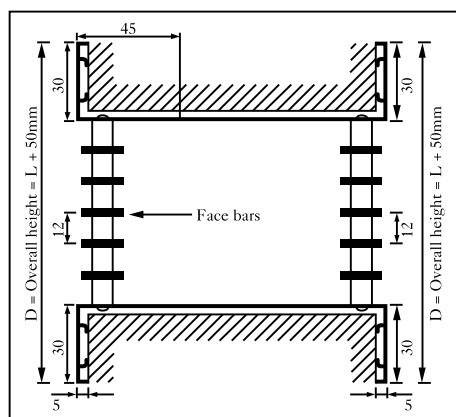

### Model: AMSG-D

Double security bar grille with steel housing.

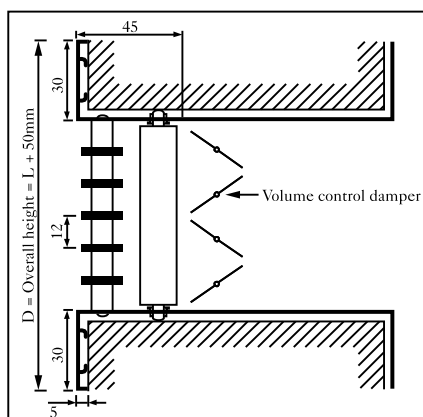

### Model: AMSR-S

Single security bar grille with volume control damper and steel housing.

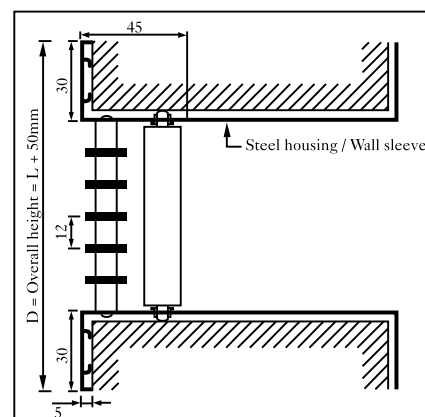

### Model: AMSG-S

Single security bar grille with steel housing.

**CONSTRUCTION:**

**Frame:** Resistant steel sheet of 4.5 mm thick with welded corners.

**Perforated Panel:** 4.5 mm thick galvanised perforated steel sheet with 8 mm holes.

**Sleeves:** Wall sleeves are made of galvanised steel.

**OPTIONAL FEATURES:**

**Damper Frame:** Galvanised steel sheet.

**Damper Core:** High quality extruded aluminium profile with natural aluminium finish and black matt finish.

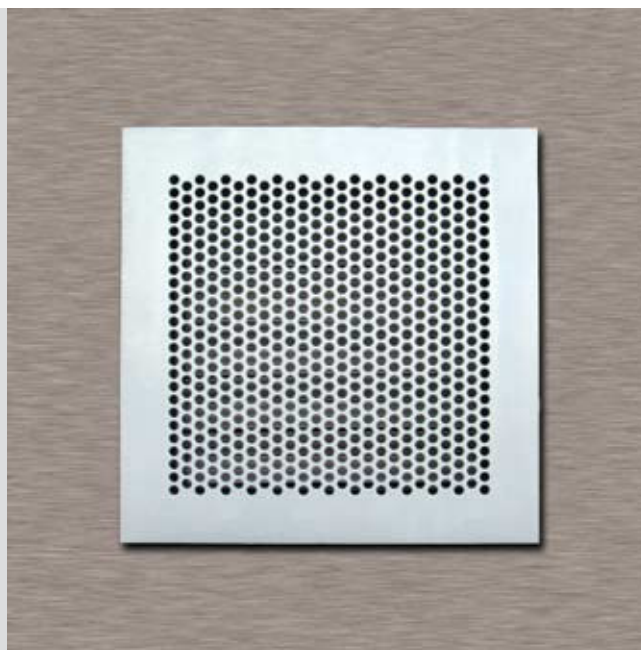
**Description:**

- Frame is constructed from 4.5 mm thick resistant steel and all sides welded with 4.5 mm thick perforated panel having 8 mm diameter holes. Whole structure is hot dip galvanised with the advantages of corrosion resistance.
- Security grilles are specially designed for maximum security prisons in order to secure the ventilation openings and provide proper air transfer for the facilities.
- The design prevents the inmates from using the grille to commit suicide
- Available with flanged edges and are supplied without fixing holes as standard.
- Available in square and rectangular sizes.

**Standard finishes:**

- Hot dip galvanised.
- Powder coated as per RAL color codes.

**Fixing:**

- 40mm x 40mm x 4mm angle frame loose supplied to be field welded on sleeve.
- Rivet fixing to the wall sleeve.
- Special damper proof screw fixing.

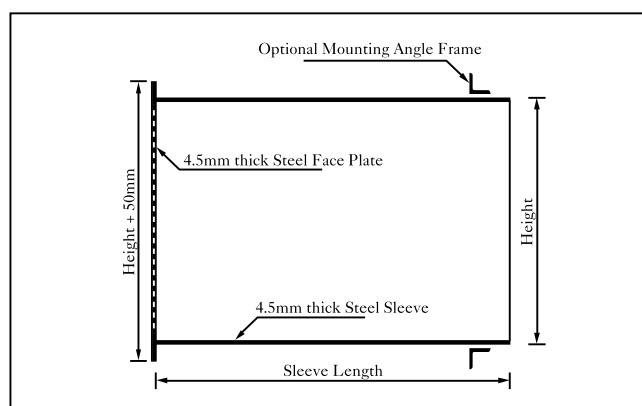

## Air flow data

Neck size in mm									
Area factor in m <sup>2</sup>									
<b>150x150</b>	Cfm	33	44	55	77	88	99	110	121
	M <sup>3</sup> /sec.	0.016	0.021	0.026	0.036	0.041	0.047	0.052	0.057
	Face velocity in m/sec	1.5	2.0	2.5	3.5	4.0	4.5	5.0	5.5
	P <sub>T</sub> in mm H <sub>2</sub> O	0.289	0.531	0.820	1.182	1.592	2.076	2.630	3.257
	Throw in m	1.1-3.7	2.3-4.9	3.1-6.0	3.7-6.6	4.3-7.2	4.9-7.8	5.5-8.1	6.0-8.6
	NC	<15	<15	<15	15	20	22	26	30
<b>200x200</b>	Cfm	64	86	107	128	150	172	193	214
	M <sup>3</sup> /sec.	0.030	0.040	0.050	0.060	0.071	0.081	0.091	0.101
	Face velocity in m/sec	1.5	2.0	2.5	3.0	3.5	4.0	4.5	5.0
	P <sub>T</sub> in mm H <sub>2</sub> O	0.265	0.483	0.748	1.086	1.496	1.930	2.461	3.040
	Throw in m	1.4-4.6	2.6-6.3	4.0-7.8	4.6-8.9	5.5-9.5	6.3-10.4	6.9-11.0	7.8-11.5
	NC	<15	<15	15	18	20	22	25	30
<b>300x300</b>	Cfm	166	221	276	331	386	442	497	552
	M <sup>3</sup> /sec.	0.078	0.104	0.130	0.156	0.182	0.209	0.234	0.260
	Face velocity in m/sec	1.5	2.0	2.5	3.0	3.5	4.0	4.5	5.0
	P <sub>T</sub> in mm H <sub>2</sub> O	0.241	0.434	0.676	0.989	1.327	1.737	2.219	2.726
	Throw in m	2.0-6.6	3.4-8.9	5.5-11.2	6.6-13.3	7.8-14.4	8.9-15.3	10.1-16.5	11.2-17.3
	NC	<15	<15	<15	16	19	24	26	30
<b>450x450</b>	Cfm	284	426	568	712	853	996	1137	1280
	M <sup>3</sup> /sec.	0.134	0.201	0.268	0.336	0.403	0.470	0.537	0.604
	Face velocity in m/sec	1.0	1.5	2.0	2.5	3.0	3.5	4.0	4.5
	P <sub>T</sub> in mm H <sub>2</sub> O	0.217	0.386	0.627	0.893	1.206	1.568	2.0	2.461
	Throw in m	2.6-9.8	4.6-13.0	7.2-16.2	9.8-19.4	11.0-21.7	13.0-23.1	14.7-24.6	16.2-26.0
	NC	<15	<15	16	19	23	27	30	32
<b>500x500</b>	Cfm	365	545	727	908	1090	1270	1453	1635
	M <sup>3</sup> /sec.	0.172	0.257	0.343	0.428	0.514	0.599	0.686	0.772
	Face velocity in m/sec	1.0	1.5	2.0	2.5	3.0	3.5	4.0	4.5
	P <sub>T</sub> in mm H <sub>2</sub> O	0.217	0.374	0.603	0.856	1.158	1.520	1.929	2.376
	Throw in m	2.9-11.3	5.1-14.9	8.1-18.7	11.3-22.3	12.9-25.3	14.9-27.0	16.8-28.7	18.7-30.4
	NC	<15	<15	16	18	24	29	32	35
<b>600x600</b>	Cfm	554	835	1113	1390	1667	1944	2225	2502
	M <sup>3</sup> /sec.	0.261	0.394	0.525	0.656	0.787	0.917	1.050	1.180
	Face velocity in m/sec	1.0	1.5	2.0	2.5	3.0	3.5	4.0	4.5
	P <sub>T</sub> in mm H <sub>2</sub> O	0.217	0.362	0.579	0.820	1.110	1.472	1.858	2.292
	Throw in m	3.1-12.7	5.7-16.7	8.9-21.1	12.7-25.1	14.7-28.9	16.7-30.9	18.8-32.7	21.1-34.7
	NC	<15	<15	15	20	25	30	34	38
<b>750x750</b>	Cfm	939	1406	1871	2337	2810	3276	3741	4208
	M <sup>3</sup> /sec.	0.443	0.663	0.883	1.103	1.326	1.546	1.766	1.986
	Face velocity in m/sec	1.0	1.5	2.0	2.5	3.0	3.5	4.0	4.5
	P <sub>T</sub> in mm H <sub>2</sub> O	0.217	0.302	0.509	0.715	1.090	1.372	1.768	2.182
	Throw in m	3.6-14.9	6.7-19.6	10.4-24.8	14.9-29.5	17.2-34.0	19.6-36.3	22.1-38.5	25.0-40.8
	NC	<15	<15	16	22	27	31	35	40

- Neck size measured in mm.
- P<sub>T</sub> - Total pressure loss is in mm of H<sub>2</sub>O.
- Throw (meters) is measured for a terminal velocities of 0.5 & 0.25 m/sec.
- Noise criteria (NC) is based on a room attenuation of 10 dB.

**CONSTRUCTION:**

**Frame:** Heavy gauge high quality extruded aluminium profile.

**Face bars:** 6 mm thick high quality aluminium bars with 12 mm pitch.

**Description:**

- Frame is constructed of high quality extruded aluminium profile with the advantages of corrosion resistance and rigidity.
- Structure is robustly constructed with face bars positioned in the frame.
- Face bars assembly is supported by heavy duty aluminium round rod.
- Applicable for installation in gymnasium, sport halls, hospitals and computer rooms.
- Suitable for sill level applications on edges of walkways, passages or raised platforms. Can be supplied in 0° deflection, 15° or 30°-1 way deflection.

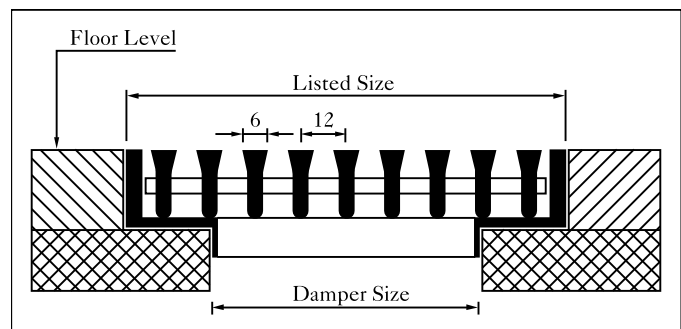
**Standard finishes:**

- Powder coated as per RAL color codes.



American University, Sharjah





## Air flow data

Width in mm A <sub>1</sub> in m <sup>2</sup>	Face Velocity in m/sec.	2.0	2.5	3.0	3.5	4.0	4.5	5.0
<b>50</b>	Cfm	89	111	133	156	178	200	222
	M <sup>3</sup> /sec.	0.042	0.053	0.063	0.074	0.084	0.095	0.105
	P <sub>s</sub> in mm H <sub>2</sub> O	0.23	0.31	0.52	0.68	0.83	1.18	1.48
	Throw in m	0.5-0.7	0.6-1.1	0.7-1.3	0.9-2.1	1.3-2.5	1.6-3.1	2.2-3.8
	NC	<20	20	22	25	27	29	30
<b>100</b>	Cfm	225	281	337	393	449	505	561
	M <sup>3</sup> /sec.	0.106	0.133	0.159	0.186	0.212	0.239	0.265
	P <sub>s</sub> in mm H <sub>2</sub> O	0.23	0.31	0.52	0.68	0.83	1.18	1.48
	Throw in m	0.7-1.3	1.3-2.8	2.3-4.1	2.5-4.8	2.8-5.4	3.5-6.4	4.1-7.3
	NC	<20	20	25	28	30	32	35
<b>150</b>	Cfm	347	434	521	608	695	782	868
	M <sup>3</sup> /sec.	0.164	0.205	0.246	0.287	0.328	0.369	0.41
	P <sub>s</sub> in mm H <sub>2</sub> O	0.23	0.31	0.52	0.68	0.83	1.18	1.48
	Throw in m	0.8-1.6	1.5-3.1	2.4-4.5	2.7-5.1	3.3-6.1	4.1-6.9	4.4-7.8
	NC	<20	20	25	27	30	33	35
<b>200</b>	Cfm	483	604	724	845	966	1087	1207
	M <sup>3</sup> /sec.	0.228	0.285	0.342	0.399	0.456	0.513	0.57
	P <sub>s</sub> in mm H <sub>2</sub> O	0.23	0.31	0.52	0.68	0.83	1.18	1.48
	Throw in m	0.9-1.8	1.7-3.7	2.5-4.8	3.1-5.4	3.5-6.7	4.4-7.3	4.9-8.2
	NC	<20	20	25	28	31	33	35
<b>250</b>	Cfm	602	752	902	1053	1203	1353	1504
	M <sup>3</sup> /sec.	0.284	0.355	0.426	0.497	0.568	0.639	0.71
	P <sub>s</sub> in mm H <sub>2</sub> O	0.23	0.31	0.52	0.68	0.83	1.18	1.48
	Throw in m	1.1-2.1	1.8-4.1	2.7-4.9	3.2-5.7	3.7-6.9	4.5-7.2	5.1-8.3
	NC	<20	20	25	27	30	32	35
<b>300</b>	Cfm	724	905	1087	1268	1449	1630	1811
	M <sup>3</sup> /sec.	0.342	0.428	0.513	0.598	0.684	0.77	0.855
	P <sub>s</sub> in mm H <sub>2</sub> O	0.23	0.31	0.52	0.68	0.83	1.18	1.48
	Throw in m	1.2-2.2	1.8-4.2	2.6-4.9	3.0-5.5	3.6-6.8	4.5-7.1	4.9-8.2
	NC	<20	20	25	28	31	33	35

- Data based on one meter unit length of the grille with damper in full open position.
- Face velocity is measured in m/sec.
- P<sub>s</sub> - Static pressure loss is in mm of H<sub>2</sub>O.
- Throw (meters) is measured for a terminal velocities of 0.5 & 0.25 m/sec.
- Noise criteria (NC) based on a room attenuation of 10 dB.

**CONSTRUCTION:**

**Frame:** Heavy gauge high quality extruded aluminium profile 4 mm thick, flange width 40 mm.

**Face bars:** 60 mm high "I" section made up of high quality extruded aluminium.

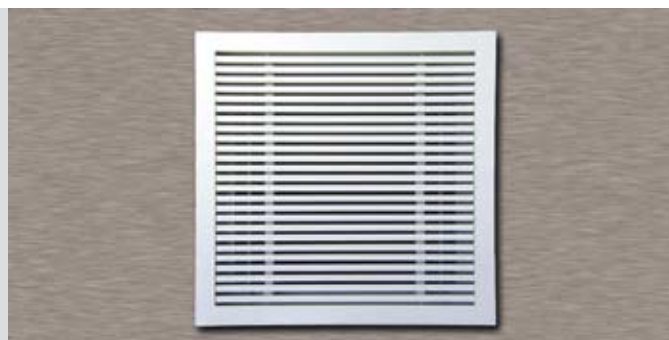
**Description:**

- Frame is constructed of high quality extruded aluminium profile with the advantages of corrosion resistance and rigidity.
- Structure is robustly constructed with face bars positioned in the frame.
- Face bars assembly is reinforced with steel rods to withstand heavy loads.
- Applicable for installation in gymnasium, sport halls, hospitals and computer rooms.
- A recess of 40 mm x 4 mm has to be provided around the grille, in the floor to install the grill flush with the floor (or) carpet level.

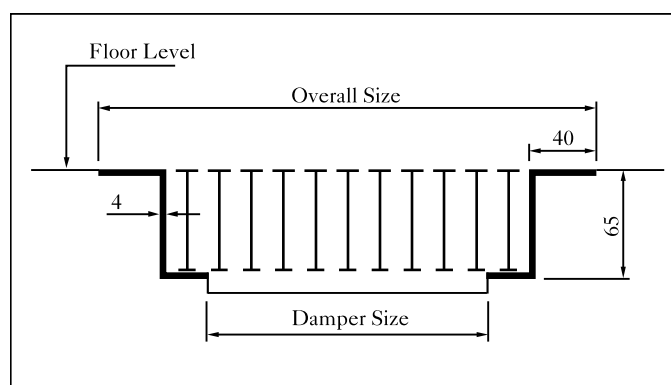
**Standard finishes:**

- Powder coated as per RAL color codes.

**Grille size 600x600 mm (Overall size)**

<b>Air Flow in CFM</b>	<b>192</b>	<b>383</b>	<b>424</b>	<b>574</b>	<b>766</b>	<b>957</b>	<b>1149</b>	<b>1340</b>
<b>Air Flow in m<sup>3</sup>/sec</b>	<b>0.091</b>	<b>0.181</b>	<b>0.200</b>	<b>0.271</b>	<b>0.362</b>	<b>0.452</b>	<b>0.542</b>	<b>0.632</b>
<b>Neck velocity in m/s</b>	0.96	1.9	2.1	2.9	3.8	4.8	5.7	6.7
<b>Pressure drop in mm of H<sub>2</sub>O</b>	0.123	0.360	0.480	0.603	0.960	1.55	2.29	3.00
<b>Throw in meters</b>	2.1	2.8	2.9	4.2	5.9	7.5	9.2	10.6
<b>NC</b>	<15	<20	20	25	29	31	33	34

- Data based on 600 x 600 mm grille.
- Face velocity is measured in m/sec.
- Noise criteria (NC) is based on room attenuation of 10 dB.

## CONSTRUCTION:

**Frame:** SS 304 grade.

**Face bars:** 3 mm thick SS 304 grade bars with 12 mm spacing as standard. 6 mm spacing as optional for damper proof applications.

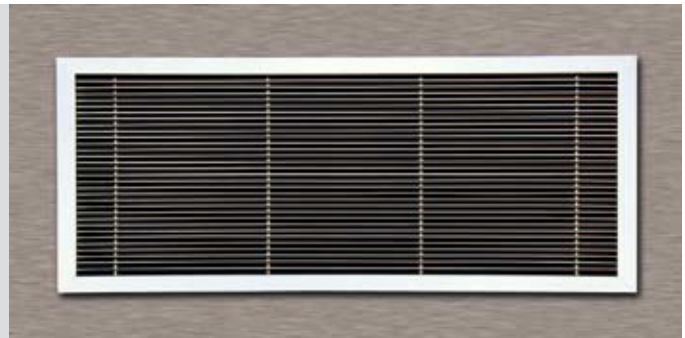

## Description:

- **Application:** Computer/server rooms, hospitals, telecommunication, food industries, oil and gas industries, airports, gymnasiums, kitchen and public areas.
- Structure is robustly designed and constructed with face bars positioned in the frame to withstand heavy loads.
- Face bars with 0° deflection is assembled and supported by heavy duty SS rod. The assembled core is removable to enable inspection, cleaning and maintenance.
- Flush type construction enables easy installation and gives even finish with the floor levels.
- Fixed core assembly is also available where in the core is welded to the frame. The frame can be connected to the plenum or support frames using screws.
- Standard sizes available are 600 mm x 600 mm for tile replacement. Custom sizes available on request according to corresponding floor levels and plenum depths.

## Standard finishes:

- Standard SS finish, polished or brush finish.

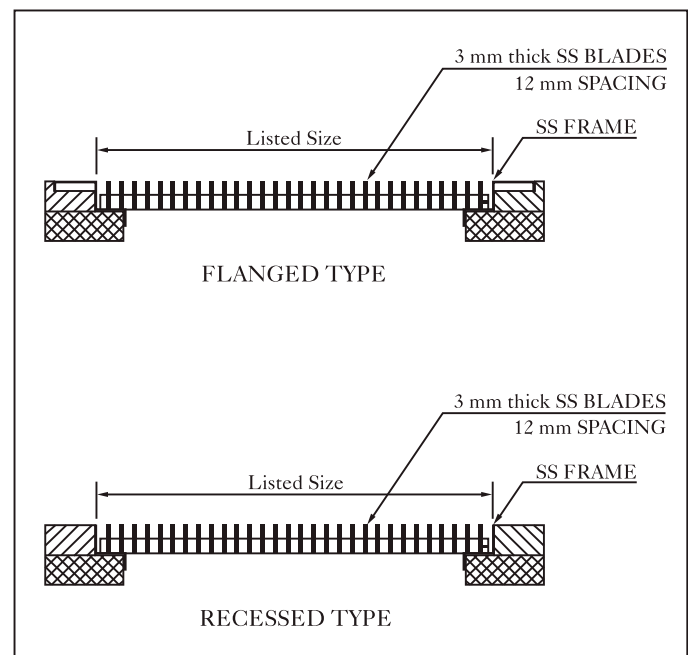



**air master**  
ISO 9001 CERTIFIED COMPANY

**AIR MASTER EQUIPMENTS EMIRATES LLC.**  
Post Box - 3180, Ajman, U.A.E.  
Tel: +971 6 7436900, 7439600 Fax: +971 6 7436700  
E-mail: [airmastr@eim.ae](mailto:airmastr@eim.ae), [sales@airmaster.ae](mailto:sales@airmaster.ae)